



PERGAMON

International Journal of Solids and Structures 36 (1999) 3735–3753

INTERNATIONAL JOURNAL OF  
**SOLIDS and  
STRUCTURES**

# Analysis of two-dimensional finite solids with microcracks

Shige Zhan, Tzuchiang Wang\*, Xueli Han

*LNM, Institute of Mechanics, Chinese Academy of Sciences, Beijing 100080, People's Republic of China*

Received 29 September 1997; in revised form 20 May 1998

---

## Abstract

A general method is presented for solving the plane elasticity problem of finite plates with multiple microcracks. The method directly accounts for the interactions between different microcracks and the effect of outer boundary of a finite plate. Analysis is based on a superposition scheme and series expansions of the complex potentials. By using the traction-free conditions on each crack surface and resultant forces relations along outer boundary, a set of governing equations is formulated. The governing equations are solved numerically on the basis of a boundary collocation procedure. The effective Young's moduli for randomly oriented cracks and parallel cracks are evaluated for rectangular plates with microcracks. The numerical results are compared with those from various micromechanics models and experimental data. These results show that the present method provides a direct and efficient approach to deal with finite solids containing multiple microcracks. © 1999 Elsevier Science Ltd. All rights reserved.

---

## 1. Introduction

Generally brittle materials contain large numbers of microcracks. Due to the presence of these microcracks, the materials become weaker and less stiff. This is of considerable interest for researchers in the fields of solid mechanics, geophysics and materials. Comprehensive reviews on this subject are given by Kachanov (1992, 1994), Nemat-Nasser and Hori (1993) and Krajcinovic (1996).

The effective moduli of microcracked solids have been attracting intensive attention in the past two decades. There are several micromechanics models to estimate the effective moduli of solids containing microcracks, such as the dilute or non-interacting solution, the self-consistent method (see e.g. Budiansky and O'Connell, 1976), the generalized self-consistent model (see e.g. Christensen and Lo, 1979), and the differential scheme (see e.g. Hashin, 1988). In these models, microcrack interactions are entirely neglected or indirectly accounted. These methods are only valid for low

---

\* Corresponding author. Tel. 00 86 10 6255 4160; Fax: 00 86 10 6256 1284; E-mail: tcwang@cc5.imech.ac.cn

or moderate crack density, since they do not depend on locations of microcracks and they do not deal with the damage and fracture process of brittle materials. The Mori–Tanaka method (Mori and Tanaka, 1973) is an effective field scheme that was applied to a 2-D cracked solid by Benveniste (1986). The analysis is reduced to consideration of one isolated crack placed into the undamaged matrix but subjected to a certain effective field, which, a priori, does not necessarily coincide with the remotely applied one. As crack density increases and microcrack spacings are closer, strong interactions between microcracks occur and the mutual positions of cracks become important. Kachanov (1987) proposed a pseudotraction method to solve multiple crack problems which took into account the strong interaction between microcracks. This method is simple and can be used to higher microcrack concentrations. But Kachanov's interaction scheme corresponds to the case in which the unknown crack-line tractions are approximated only by their average. Huang et al. (1996) used a hybrid BEM method, in conjunction with a unit cell model, to calculate the effective moduli of microcracked solids. A unit cell, which can be considered as a representative block in the solid, is assumed to be periodic in the solid so as to account for interactions between cracks inside and outside the cell. The effective moduli based on this numerical method for randomly distributed cracks and parallel cracks were compared with those from various micromechanics models. It is noted that the foregoing methods are only used in infinite media. However, it is difficult to verify these models by experimental data since specimens are finite.

Vavakin and Salganik (1975) conducted uniaxial tension tests on a thin elastic sheet containing an array of randomly oriented slits. Carvalho and Labuz (1996) presented the results of experiments designed to measure effective elastic properties of artificially cracked and porous aluminum plates under plane stress conditions. Chau and Wong (1997) compared the predicted effective moduli by the self-consistent and non-interacting methods to experimental observations on natural rocks containing microcracks and artificial rocks containing inserted microcracks. Their results indicate that the non-interacting theory and self-consistent method are only applicable if the crack density is smaller than 0.2. A better damage model is needed for solids with crack density larger than 0.2.

Fond and Berthaud (1995) used the pseudotractions technique to deal with interactions between cracks and circular cavities in two-dimensional finite or infinite media. The effects of interactions and the presence of boundaries are illustrated by some examples considering the global stiffness of cracked media under tensile loading. Jiang et al. (1996) considered the problem of interacting micro-cracks around an inclusion in a system involving complex finite geometries and general boundary conditions. A hybrid micro-macro BEM formulation capable of handling interactions among the inclusion, arbitrarily distributed cracks and the boundaries of the system was developed. Renaud et al. (1996) investigated the impact of interactions on the effective stiffness of microcracked media by means of an indirect boundary element method, namely the displacement discontinuity method. For tensile loadings, and when only crack–crack interactions were considered, their numerical results showed good agreement with the non-interacting crack approximation. When microcrack–boundary interactions were also taken into account, the results agreed rather well with the differential scheme. Krajcinovic (1996, 1997) used percolation models to estimate the effective material properties in the limit of large defect concentration.

The literature related to the variational bounds of the effective properties is abundant. The best known and most commonly used inequality has been suggested by Hashin and Shtrikman (1963) and the whole field has been reviewed by several authors (see e.g. Willis, 1981; Hashin, 1983; Torquato, 1992). The bounds on the effective elastic properties of materials with a heterogeneous

microstructure can be determined from the corresponding expressions for the effective conductivity (see e.g. Torquato, 1992; Milton, 1984; Gibiansky and Torquato, 1993). Recently, Gibiansky and Torquato (1996) found the bounds on the effective elastic moduli of cracked materials in terms of the effective conductivity of such media that were valid for arbitrary shapes and spatial distribution of the cracks. These results are very valuable for the experimental determination of the effective elastic moduli.

Recently, statistical models have been emerging which attempts to grasp the intrinsic randomness of material microstructure and the ensuing unpredictability of damage processes. Lattice models and similar models are used to study the random fracture and damage problem (see e.g. Skjeltorp and Meakin, 1988; Herrmann and Roux, 1990; Curtin and Scher, 1990; Ray and Chakrabarti, 1985; Harlow and Phoenix, 1991; Ostoja-Starzewski and Lee, 1996; Schlangen and Garbozi, 1996; Chiaia et al., 1997). Mazars (1983), and Breyse and Schmitt (1991) formulated rather elaborate statistical models for microcracking in concrete. Bai et al. (1991) presented a statistical model to study statistical evolution of microcracks. Ju and Chen (1994) presented a two-dimensional statistical micromechanical theory for microcrack-weakened brittle solids based on the concepts of ensemble-average and microcrack interaction. Diao (1996) established the new statistical theory of inhomogeneous damage by the non-equilibrium statistical method which can universally describe the evolution of the damage parameter with time due to the initiation and growth of damaged regions in the material.

The purpose of the present study is to give an accurate and efficient method for solving the plane elasticity problem of finite solids with multiple microcracks. The problem of a homogeneous finite plate with microcracks can be decomposed into two subproblems. The first is the problem of the microcrack interactions within an imaginary finite region in an infinite plate and no stress is applied at infinity. The configurations of microcracks and the opening displacement of each microcrack inside the imaginary finite region are the same as those of the original problem. The second is a homogeneous problem, in which the finite plate of matrix material is subjected to the loadings. The loadings consist of the same external loading as in the original problem and the extra loadings which are applied in order to counteract the tractions induced by microcrack interactions along the boundary of the imaginary finite region in the first problem. Analysis is based on a superposition scheme and series expansions of the complex potentials. By using the traction-free conditions on each crack surface and resultant force relations along the outer boundary, a set of governing equations are formulated. The governing equations are solved numerically on the basis of a boundary collocation procedure. The effective Young's moduli based on this method for randomly distributed cracks and parallel cracks are evaluated for rectangular plated with microcracks. The numerical results are compared with those from various micromechanics models and experimental data.

## **2. Basic formulae and calculation method**

### *2.1. Basic formulae*

#### *2.1.1 A single crack*

It is well known that stresses and displacements for a homogeneous elastic body under plane deformation can be represented by two complex potentials. To be convenient for our purpose, potentials  $\Phi(z)$  and  $\Omega(z)$  will be used. Stresses can be derived from (Muskhelishvili, 1953)

$$\begin{aligned}\sigma_x + \sigma_y &= 2[\Phi(z) + \overline{\Phi(z)}] \\ \sigma_y - i\sigma_{xy} &= \Phi(z) + \Omega(z) + (z - \bar{z})\overline{\Phi'(z)}\end{aligned}\quad (1)$$

A crack can be considered as a continuous distribution of infinitesimal edge dislocation. For a single crack lying on the real axis between  $s = -a$  and  $s = a$  in an infinite plate, the complex potentials  $\Phi(z)$  and  $\Omega(z)$  are given by the following formula:

$$\Phi(z) = \Omega(z) = \frac{\mu}{\pi i(\kappa + 1)} \int_{-a}^a \frac{g(s)}{z - s} ds \quad (2)$$

where  $g(s)$  is the dislocation density at point  $z = s$  on the crack surface. For the plane strain problem  $\kappa = 3 - 4\nu$ , for the plane stress problem  $\kappa = (3 - \nu)/(1 + \nu)$ .  $\mu$  is the shear modulus and  $\nu$  is Poisson's ratio.

The dislocation density can be expressed as the following series:

$$\frac{\mu}{i(\kappa + 1)} g(s) = \sum_{m=0}^{\infty} \alpha_m \frac{T_m(\xi)}{\sqrt{1 - \xi^2}} \quad (3)$$

where  $T_m(\xi)$  is Chebyshev polynomials of the first kind and  $\xi = s/a$ .

Then, substituting eqn (3) into eqn (2), we obtain

$$\Phi(z) = \Omega(z) = \sum_{m=0}^{\infty} \alpha_m \left( \frac{z}{a} - \sqrt{\frac{z^2}{a^2} - 1} \right)^m \bigg/ \sqrt{\frac{z^2}{a^2} - 1} \quad (4)$$

In derivation of eqn (4), the following formula is used,

$$\frac{1}{\pi} \int_{-1}^1 \frac{(1 - \xi^2)^{-1/2} T_m(\xi) d\xi}{z - \xi} = (z - \sqrt{z^2 - 1})^m / \sqrt{z^2 - 1}, \quad m = 0, 1, 2, \dots$$

Equation (4) has been independently proposed by Gross (1982) and Han and Wang (1996) from different points of view.

Substituting eqn (4) into eqn (1), the stress field at any point due to the crack can be expressed as a series. Especially the stress field on the crack surface can be expressed as

$$\sigma_y - i\sigma_{xy} = \Phi^+(s) + \Omega^-(s) = -2 \sum_{m=0}^{\infty} \alpha_m U_{m-1}(s/a) \quad (5)$$

where  $U_m(s/a)$  is Chebyshev polynomials of the second kind.

The unknown coefficients  $\alpha_m$  need to be determined. Due to the closure condition at the crack tips, the following equation can be given

$$\int_{-a}^a g(s) ds = \frac{ia(\kappa + 1)}{\mu} \sum_{m=0}^{\infty} \alpha_m \int_{-1}^1 \frac{T_m(\xi) d\xi}{\sqrt{1 - \xi^2}} = 0 \quad (6)$$

According to the orthogonality of Chebyshev polynomials of the first kind, it is easily shown that

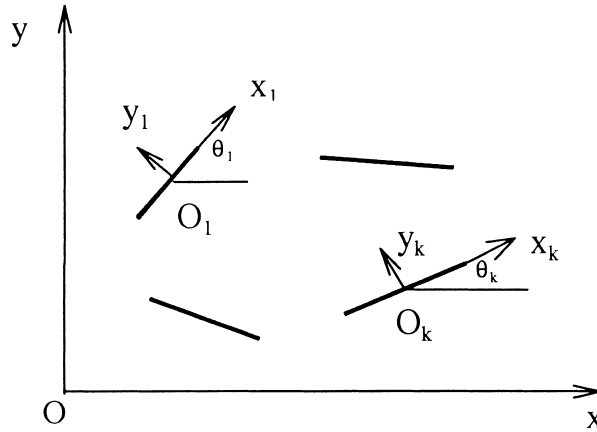

Fig. 1. A set of arbitrary cracks.

$$\alpha_0 = 0 \tag{7}$$

2.1.2. A set of arbitrary cracks

A system containing a set of arbitrary 2-D of  $N$  cracks in an infinite plate is shown in Fig. 1. A global Cartesian coordinate system  $Oxy$  is situated. A local normal-tangential coordinate system employed with origin ( $O_k$ ) at the center of the  $k$ -th crack is represented by  $x_k$  and  $y_k$ . The geometry of the  $k$ -th crack is specified by the center coordinates  $(x_c^{(k)}, y_c^{(k)})$ , orientation angle  $\theta_k$ , and the half length of the crack  $a_k$ .

The stresses produced by the  $k$ -th crack in the local coordinate system  $O_kx_ky_k$  take the form

$$\begin{aligned} \sigma_{xk} + \sigma_{yk} &= 2[\Phi_k(z_k) + \overline{\Phi_k(\bar{z}_k)}] \\ \sigma_{yk} - i\sigma_{xyk} &= \Phi_k(z_k) + \Omega_k(\bar{z}_k) + (z_k - \bar{z}_k)\overline{\Phi_k'(z_k)} \end{aligned} \tag{8}$$

where

$$\Phi_k(z_k) = \Omega_k(z_k) = \sum_{m=0}^{\infty} \alpha_{km} \left( \frac{z_k}{a_k} - \sqrt{\frac{z_k^2}{a_k^2} - 1} \right)^m \bigg/ \sqrt{\frac{z_k^2}{a_k^2} - 1}$$

$$\begin{aligned} z_k &= x_k + iy_k = (z - C_k) e^{-i\theta_k} \\ z &= x + iy, \quad C_k = x_c^{(k)} + iy_c^{(k)} \end{aligned}$$

and on the  $k$ -th crack surface

$$\sigma_{yk}^{(k)}(x_k) - i\sigma_{xyk}^{(k)}(x_k) = \Phi^+(x_k) + \Omega^-(x_k) = -2 \sum_{m=0}^{\infty} \alpha_{km} U_{m-1}(x_k/a_k) \tag{9}$$

According to the formulae of coordinate system transformation, the tractions along the  $l$ -th crack surface in local coordinate system  $O_lx_ly_l$  produced by the  $k$ -th crack can be written as follows

$$\sigma_{yl}^{(k)}(z_l) - i\sigma_{xyl}^{(k)}(z_l) = \frac{1}{2}[\sigma_{xk}(z_k) + \sigma_{yk}(z_k)](1 - e^{-2i\theta}) + [\sigma_{yk}(z_k) - i\sigma_{xyz}(z_k)]e^{-2i\theta}$$

$$k = 1, 2, \dots, N \quad (10)$$

where

$$\theta = \theta_l - \theta_k, \quad z_k = (C_l - C_k)e^{-i\theta_k} + z_l e^{i(\theta_l - \theta_k)}$$

## 2.2. Solution for rectangular plate under tension

As mentioned in Section 1, the problem of a finite plate with microcracks can be decomposed into two subproblems. The first subproblem is microcrack interactions within an imaginary finite region in an infinite plate and no stress is applied at infinity. The configurations of microcracks and the opening displacement of each microcrack inside the imaginary finite region are the same as that of the original problem. The second is a homogeneous problem in which the homogeneous finite plate of matrix material is subjected to the loadings. The loadings consist of the same external loading as in the original problem and the extra loadings which are applied in order to counteract the tractions induced by microcrack interactions along the boundary of the imaginary finite region in the first problem and satisfy the outer boundary condition of the finite plate. The basic formulae in the first subproblem have been derived in Section 2.1. In the second subproblem, the stresses caused by the loads applied at the outer boundary can be expressed by two complex potentials  $\Phi_0(z)$  and  $\Omega_0(z)$ :

$$\sigma_x^{(0)} + \sigma_y^{(0)} = 2[\Phi_0(z) + \overline{\Phi_0(z)}]$$

$$\sigma_y^{(0)} - i\sigma_{xy}^{(0)} = \Phi_0(z) + \Omega_0(z) + (z - \bar{z})\overline{\Phi_0'(z)} \quad (11)$$

where

$$\Phi_0(z) = \sum_{n=1}^{\infty} nb_n z^{n-1}, \quad \Omega_0(z) = \sum_{n=1}^{\infty} nc_n z^{n-1}$$

According to the superposition scheme, the traction-free condition on each crack surface can be written as follows

$$\sigma_{yl}^{(0)}(x_l) - i\sigma_{xyl}^{(0)}(x_l) + \sum_{k=1}^N [\sigma_{yl}^{(k)}(x_l) - i\sigma_{xyl}^{(k)}(x_l)] = 0, \quad |x_l| < a_l, \quad l = 1, 2, \dots, N \quad (12)$$

where  $\sigma_{yl}^{(k)}(x_l) - i\sigma_{xyl}^{(k)}(x_l)$  are the tractions along the  $l$ -th microcrack surface in local coordinate system  $O_l x_l y_l$  produced by the  $k$ -th microcrack in the first subproblem.  $\sigma_{yl}^{(0)}(x_l) - i\sigma_{xyl}^{(0)}(x_l)$  are the tractions along the  $l$ -th microcrack surface in local coordinate system  $O_l x_l y_l$  produced by the loadings applied to the outer boundary of the finite plate in the second subproblem.

Consider a rectangular plate with microcracks which is subjected to external uniaxial tension (Fig. 2). Point  $A$  is assumed to be fixed at all times, a point  $A^*$  is permitted to move. The boundary conditions in the present analysis are written in terms of resultant forces from  $A$  to  $A^*$  as follows:

$$A^* \in AB: \quad X + iY = 0$$

$$A^* \in BC: \quad X + iY = \sigma_0 i(W - x)$$

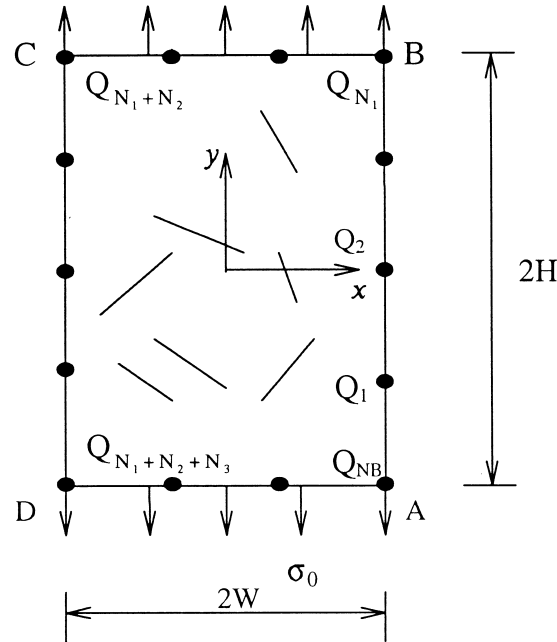

Fig. 2. Tension of rectangular plate with microcracks.

$$A^* \in CD: X + iY = 2\sigma_0 iW$$

$$A^* \in DA: X + iY = \sigma_0 i(W - x) \tag{13}$$

In the global coordinate system, the resultant forces from  $A$  to  $A^*$  can be expressed

$$\begin{aligned} X(z) + iY(z) &= X_0(z) + iY_0(z) + \sum_{k=1}^N (X_k(z_k) + iY_k(z_k)) e^{i\theta_k} \\ &= -i[\phi_0(z) + \omega_0(\bar{z}) + (z - \bar{z})\overline{\Phi_0(z)}]_{A^*} \\ &\quad - \sum_{k=1}^N i\{[\phi_k(z_k) + \omega_k(\bar{z}_k) + (z_k - \bar{z}_k)\overline{\Phi_k(z_k)}] e^{i\theta_k}\}_{A^*} \end{aligned} \tag{14}$$

where

$$\begin{aligned} \phi_0(z) &= \sum_{n=0,1}^{\infty} b_n z^n, \quad \omega_0(z) = \sum_{n=0,1}^{\infty} c_n z^n \\ \phi_k(z_k) &= \omega_k(z_k) = - \sum_{m=1}^{\infty} \frac{a_k}{m} \alpha_{km} \left( \frac{z_k}{a_k} - \sqrt{\frac{z_k^2}{a_k^2} - 1} \right)^m \end{aligned}$$

Equations (12) and (13) are the governing equations for determining the unknown coefficients  $\alpha_{km}$  ( $k = 1, 2, \dots, N; m = 1, 2, \dots, \infty$ ),  $b_n$  ( $n = 0, 1, \dots, \infty$ ) and  $c_n$  ( $n = 0, 1, \dots, \infty$ ).

It is difficult to solve the governing equations analytically. The governing equations can be reduced to a system of linear algebraic equations for the unknown coefficients based on the boundary collocation method on crack surfaces and the outer boundary of the rectangular plate. By means of dividing the  $k$ -th crack surface into  $M_k$  elements, the collocation points on the  $k$ -th crack surface are given by the following expression

$$x_{ki} = a_k \cos\left(\frac{i\pi}{M_k + 1}\right), \quad i = 1, 2, \dots, M_k$$

The  $i$ -th outer edge of the rectangular plate is divided regularly into  $N_i$  ( $i = 1, 2, 3, 4$ ) segments by selecting the boundary stations  $Q_j(z_j)$  ( $j = 1, 2, \dots, NB$ ), where  $NB = \sum_{i=1}^4 N_i$ ,  $Q_1$ ,  $Q_2$  and  $Q_{NB}$  are taken as shown in Fig. 2.

When the algebraic equations are solved, the complex potentials and the stress components produced by each crack and the loadings applied to the outer edges are known. According to the superposition principle, the stress fields of the rectangular plate are obtained with the aid of the transformation formulas from the local coordinate systems into the global one.

### 3. SIFs and the effective elastic moduli

The stress intensity factors are related to stresses on the prolongation of the microcracks by

$$k_{1l}^{\pm} - ik_{2l}^{\pm} = \lim_{x_l \rightarrow \pm a_l} \sqrt{\pi} \sqrt{\frac{x_k^2 - a_l^2}{a_l}} [\sigma_{yl}(x_l) - i\sigma_{xyl}(x_l)] \quad |x_l| > a_l, \quad (l = 1, 2, \dots, N) \quad (15)$$

and they can be further expressed as

$$k_{1l}^{\pm} - ik_{2l}^{\pm} = \pm 2\sqrt{\pi a_l} \sum_m \alpha_{lm} T_m(\pm 1), \quad l = 1, 2, \dots, N \quad (16)$$

Here the quantities with upper and lower signs refer to the right- and left-hand microcrack tips, respectively.

According to the work by Kachanov (1992), for flat cracks in 2-D, the average strains can be expressed:

$$\begin{aligned} \langle \boldsymbol{\varepsilon} \rangle &= \mathbf{M}^0 : \langle \boldsymbol{\sigma} \rangle + \frac{1}{2A} \sum_l (\langle \mathbf{b} \rangle \mathbf{n} + \mathbf{n} \langle \mathbf{b} \rangle)^l a^l \\ &= (\mathbf{M}^0 + \Delta \mathbf{M}) : \langle \boldsymbol{\sigma} \rangle = \mathbf{M} : \langle \boldsymbol{\sigma} \rangle \end{aligned} \quad (17)$$

where  $\mathbf{M}^0$  is the compliance tensor of the matrix material;  $\langle \boldsymbol{\sigma} \rangle$  is the average stress, which is equal to the stresses imposed on the rectangular plate; and  $\mathbf{M}$  is the effective compliance;  $A$  is the area of the rectangular plate; the superscript ( $l$ ) denotes the  $l$ -th microcrack in the plate; the summation is over all microcrack;  $a^l$  is the half length of the  $l$ -th crack.  $(\langle \mathbf{b} \rangle \mathbf{n})^l$ ,  $(\mathbf{n} \langle \mathbf{b} \rangle)^l$  denote dyadic (tensor) products of the displacement discontinuity vector  $\mathbf{b}^{(l)} = \mathbf{u}^{(l)+} - \mathbf{u}^{(l)-}$  (crack opening displacement, COD) and unit normal  $\mathbf{n}^{(l)}$  to the  $l$ -th crack. The average COD of the  $l$ -th crack can be calculated by the following formulae:



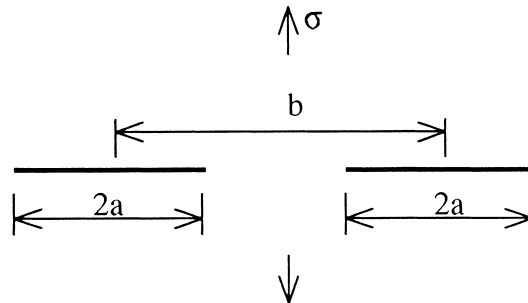

Fig. 3. Two collinear cracks under uniform tension.

$$\langle \mathbf{b} \rangle^I = \frac{1}{2a_l} \int_{-a_l}^{a_l} \mathbf{b}' dx_l = \frac{a_l \pi (\kappa + 1)}{4\mu} \alpha_{l1} i \quad (18)$$

For the uniaxial tension case (Fig. 2), we can obtain the effective compliance  $M_{22}$ , then the effective moduli can be calculated  $E_2 = 1/M_{22}$ .

## 4. Numerical examples

### 4.1. Two or several cracks in an infinite plate

As a first example, consider an infinite plate containing two collinear cracks, as shown in Fig. 3, under remote tension loading. In order to check the accuracy and convergency of the present method, the stress intensity factors are calculated for increasing numbers of collocation points along the crack surface  $M_k$ . The normalized stress intensity factors are given in Table 1, along with the analytical exact results (Murakami, 1987). Table 1 shows that the numerical convergency of the present method is excellent and the accuracy is very high. The six digits accuracy can be obtained with six or eight collocation points when the distance between two crack tips is large; more collocation points are needed in order to obtain higher accuracy as crack spaces are closer. When  $2a/b$  is 0.4 and the number of collocation points is eight, the differences of the tractions between the present results and the analytic solutions are less than  $10^{-15}\sigma$  at the collocation points on the crack surface, and those at the middle points between neighboring collocation points are less than  $10^{-8}\sigma$ .

For an infinite row of collinear cracks with the same length (as show in Fig. 4) under remote tension loading, the normalized stress intensity factors are shown in Table 2, which coincide with the literature (Murakami, 1987).

Numerical tests have shown that the accuracy and the efficiency of the present method are very high, indicating that this method could be used as a tool to study the damage problems of brittle materials which are weakened by many cracks.

Table 1  
Normalized stress intensity factors  $K_I/\sigma\sqrt{\pi a}$  for geometry of Fig. 3

$2a/b$	$M_k$	Outside		Inside	
		Present	Exact*	Present	Exact*
0.10	4	1.001196	1.00120	1.001322	1.00132
	6	1.001196		1.001322	
0.20	4	1.004624	1.00462	1.005660	1.00566
	6	1.004624		1.005660	
0.30	4	1.010166	1.01017	1.013828	1.01383
	6	1.010167		1.013831	
	8	1.010167		1.013831	
0.40	4	1.017857	1.01787	1.027153	1.02717
	6	1.017867		1.027170	
	8	1.017867		1.027170	
0.50	6	1.027952	1.02795	1.047958	1.04796
	8	1.027953		1.047960	
	10	1.027953		1.047960	
0.60	8	1.040936	1.04094	1.080403	1.08040
	10	1.040937		1.080404	
	12	1.040937		1.080404	
0.70	8	1.057861	1.05786	1.133253	1.13326
	10	1.057864		1.133262	
	12	1.057864		1.133262	
0.80	12	1.081066	1.08107	1.228933	1.22894
	14	1.081067		1.228935	
	16	1.081067		1.228935	
0.90	12	1.117394	1.11741	1.453709	1.45387
	16	1.117411		1.453859	
	20	1.117411		1.453869	

\* See Murakami (1987).

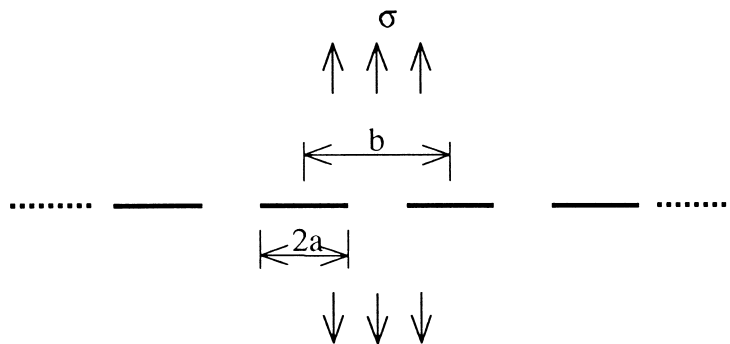

Fig. 4. An infinite row of parallel cracks.

Table 2  
Normalized stress intensity factors  $K_I/\sigma\sqrt{\pi a}$  for geometry of Fig. 4

$2a/b$	Present	Isida*	$2a/b$	Present	Isida*
0.1	1.004147	1.00415	0.5	1.128379	1.12838
0.2	1.016981	1.01698	0.6	1.208468	1.20847
0.3	1.039832	1.03983	0.7	1.336007	1.33601
0.4	1.075327	1.07533	0.8	1.564973	1.56497

\* See Murakami (1987).

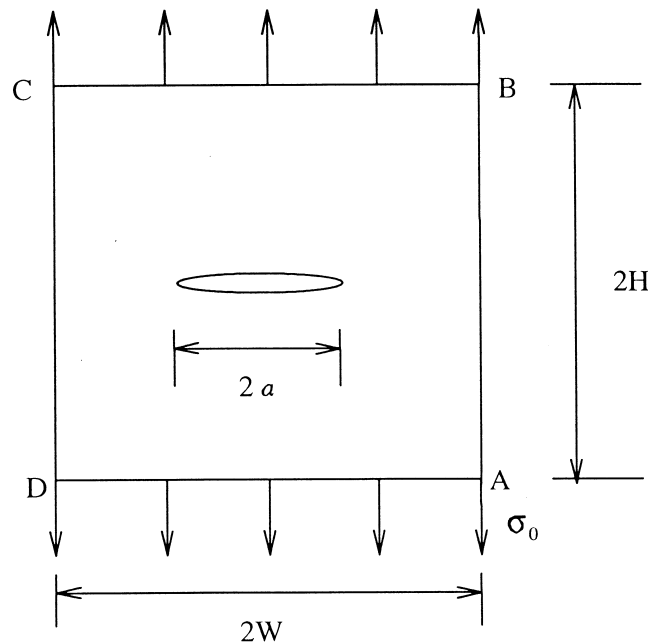

Fig. 5. Uniform tension of center cracked rectangular plate.

#### 4.2. Uniform tension of center cracked rectangular plate

A rectangular plate with a center crack is subjected to uniform tension as shown in Fig. 5. The number of collocation points on the crack surface is eight, and the number of collocation points of outer boundary is 60 ( $NB = 60$ ). The normalized stress intensity factors are given in Table 3, which are in good agreement with Isida's solutions (Murakami, 1987). When  $a/W$  is 0.4, the normal stresses along  $BC$  are shown in Fig. 6, and the absolute values of the shear stresses along  $AB$  and  $BC$  are less than  $10^{-3}\sigma_0$ . The results show the present method is efficient for solving the crack problem of a finite solid.

Table 3

Normalized stress intensity factors  $K_I/\sigma_0\sqrt{\pi a}$  for geometry of Fig. 5 ( $\alpha = a/W, \beta = H/W = 1$ )

$\alpha$	0	0.1	0.2	0.3	0.4	0.5	0.6	0.7
Present	1.000	1.0140	1.0553	1.1232	1.2162	1.3342	1.4843	1.685
Isida*	1.000	1.014	1.055	1.123	1.216	1.334	1.481	1.68

\* See Murakami (1987).

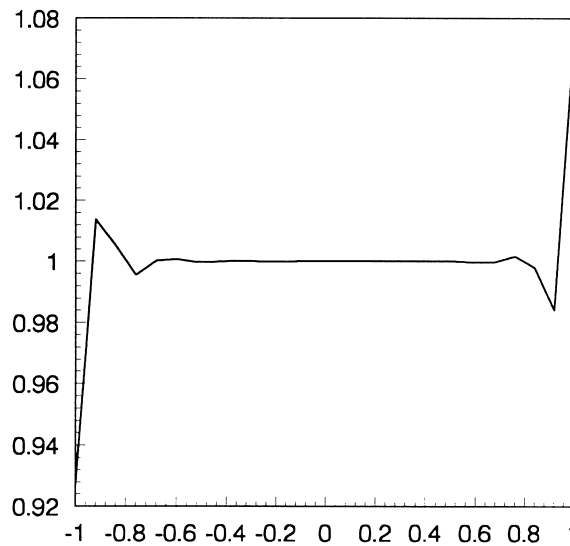
Fig. 6. The normalized normal stresses along  $BC$  ( $a/W = 0.4$ ).

#### 4.3. Uniform tension of rectangular plate with microcracks

In the present work, crack density is the parameter that characterizes the effect of microcracking. Following Budiansky and O'Connell (1976), the crack density is defined for a microcracked solid (2-D) as

$$\rho = \frac{1}{A} \sum_{i=1}^N a_i^2 \quad (19)$$

where  $N$  is the number of microcracks,  $a_i$  is the half length of the  $i$ -th microcrack. The Poisson's ratio of the matrix material is 0.3. The present study is limited to plane stress analysis.

First, we calculate the effective Young's moduli of a square plate containing randomly oriented cracks and parallel cracks. Thirty-six microcracks with the same length are generated in the square plate and the number of cracks is fixed. The rectangular plate is divided uniformly into meshes in order for each mesh to contain one microcrack. Locations and orientations of microcracks are

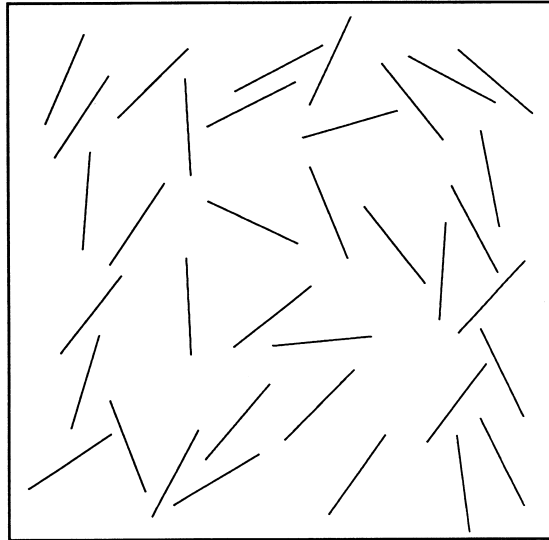

Fig. 7. Randomly oriented cracks.

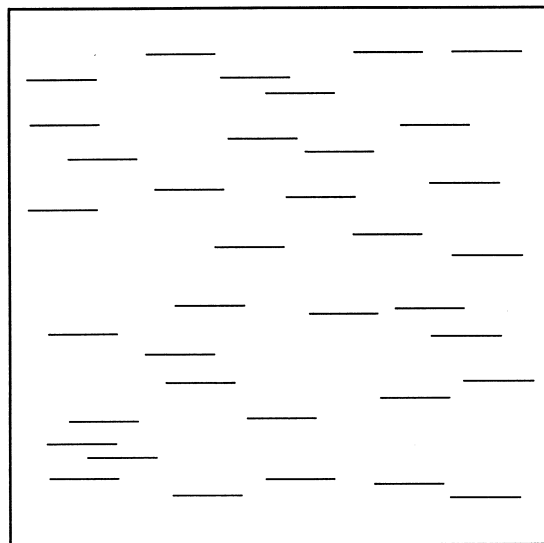

Fig. 8. Parallel cracks.

randomly generated in each mesh (for parallel cracks, microcracks are randomly generated in locations, but are parallel to the  $x$  direction) (Figs 7 and 8). For each orientation statistics, six crack densities are assumed:  $p = 0.10; 0.15; 0.20; 0.25; 0.30; 0.35$ . Fifteen sample arrays are considered for each density. The crack densities are increased by increasing the length of all cracks and maintaining the same random number for each particular crack distribution. In the course of

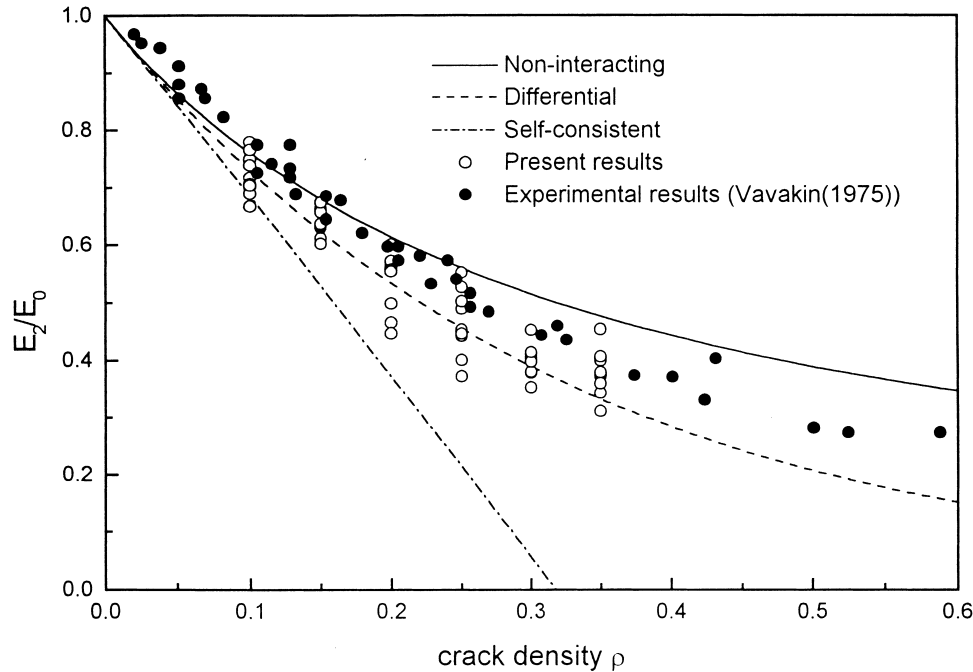

Fig. 9. Normalized effective Young's moduli  $E_z/E_0$  vs crack density  $\rho$  (randomly oriented cracks,  $N = 36$ ).

generation, they are regenerated if there is an intersection among cracks or an intersection between microcracks and the boundary. The effective Young's moduli are calculated for each crack distribution,

For randomly oriented cracks, the effective Young's moduli are shown in Fig. 9, along with the solutions of other micromechanics models and the experimental data (Vavakin and Salganik, 1975). For parallel cracks, the effective Young's moduli are presented in Fig. 10. As shown in these figures, the results are scattered from one sample to another. For randomly oriented cracks, the mean of the moduli is close to the solution from the differential method, which agrees well with the results of Huang et al. (1996), Fond and Berthaud (1995) and Renaud et al. (1996). The present results are in agreement with the experimental data (Vavakin and Salganik, 1975). For parallel cracks, the range of variation in the moduli is below that for the dilute or non-interacting solution and above that for the differential solution, which coincides with Huang's results (Huang et al., 1996). In addition, the effective moduli are computed within the representative volume element (RVE) in an infinite matrix based on the present method for randomly distributed cracks and parallel cracks. The average stresses and strains in the RVE are calculated by means of Kachanov's method (see e.g. Kachanov, 1992, 1994). The results showed good agreement with Kachanov's results (see e.g. Kachanov, 1992, 1994). For randomly distributed cracks, the approximation of non-interacting cracks provides surprisingly good results, indicating the cancellation of microcrack shielding and amplifying in the RVE in an infinite media. Further, the effective moduli of the square plate with multiple microcracks, obtained by using the present method, are compared with the results of Kachanov (1992, 1994) based on the RVE in an infinite matrix in Figs 11 and 12.

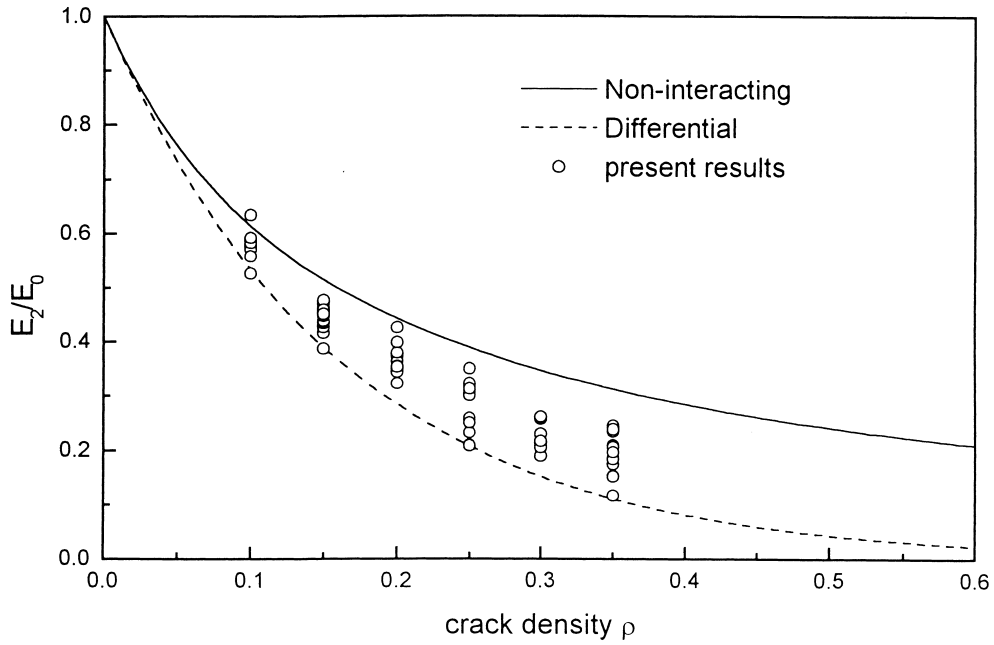

Fig. 10. Normalized effective Young's moduli  $E_2/E_0$  vs crack density  $\rho$  (parallel cracks,  $N = 36$ ).

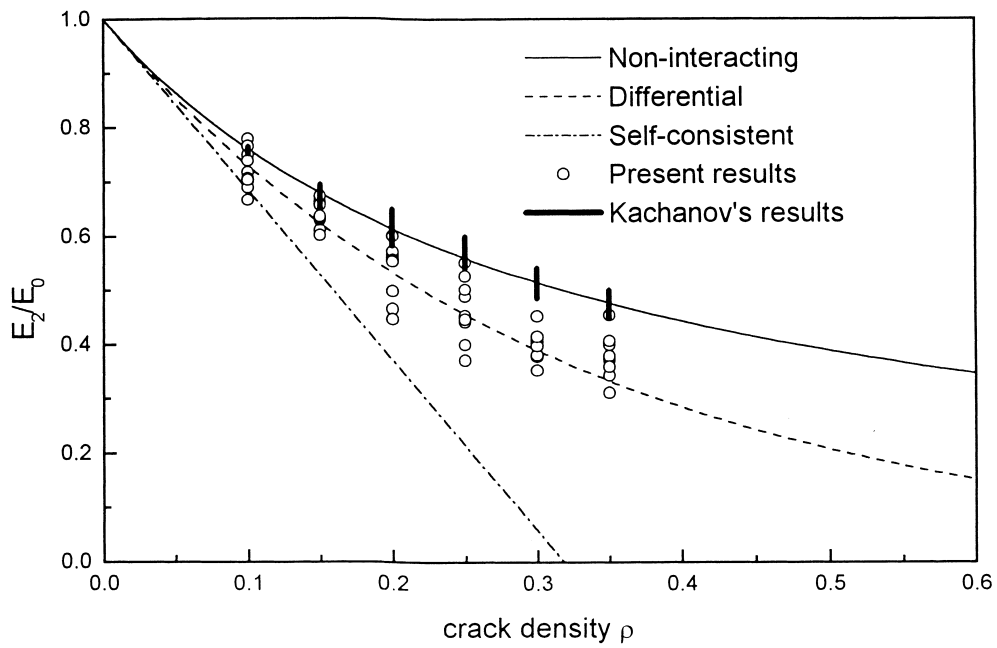

Fig. 11. Normalized effective Young's moduli  $E_2/E_0$  vs crack density  $\rho$  (randomly oriented cracks).

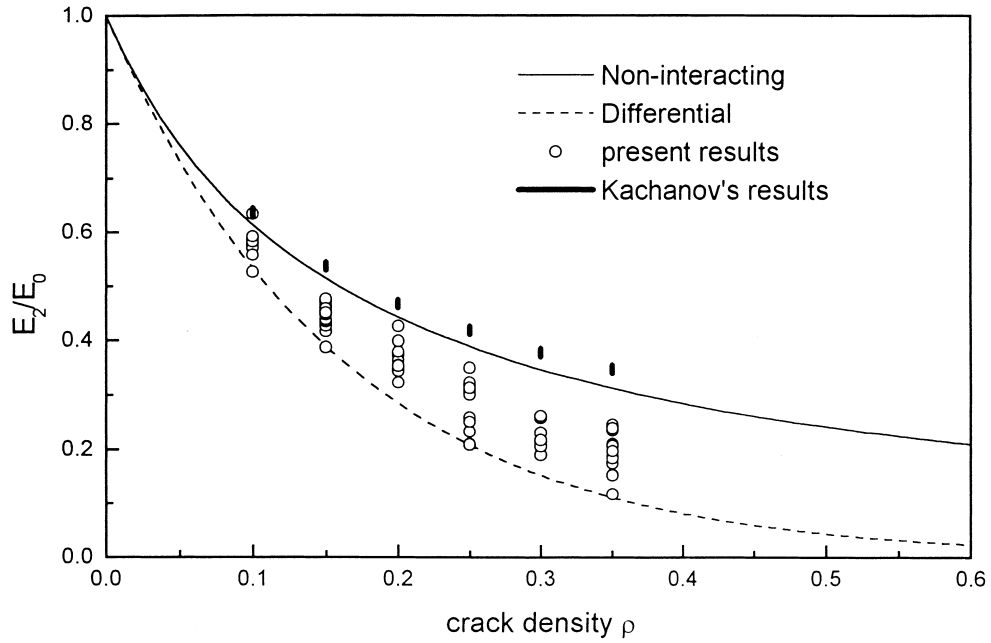

Fig. 12. Normalized effective Young's moduli  $E_2/E_0$  vs crack density  $\rho$  (parallel cracks).

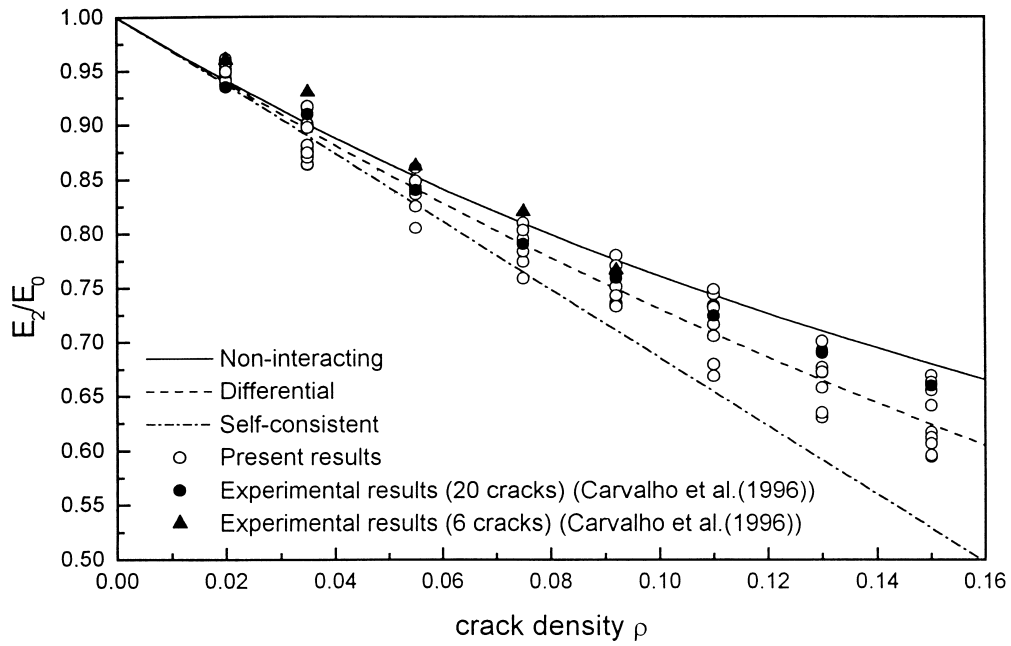

Fig. 13. Normalized effective Young's moduli  $E_2/E_0$  vs crack density  $\rho$  (randomly oriented cracks,  $N = 6$ ).



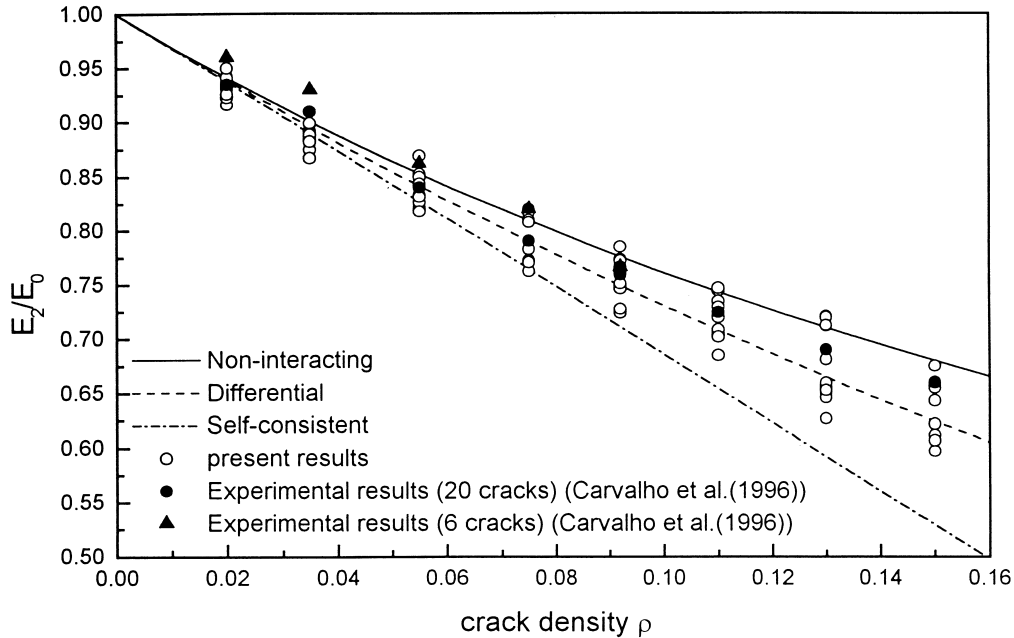

Fig. 14. Normalized effective Young's moduli  $E_2/E_0$  vs crack density  $\rho$  (randomly oriented cracks,  $N = 20$ ).

From the comparison of the results, it can be found that our results are below those from Kachanov's method which indicates that the presence of outer boundaries increases the loss of stiffness.

In order to compare the solutions of the present method with the experimental results (Carvalho and Labuz, 1996), the effective Young's moduli are also calculated for the specimens. The ratio  $W/H$  of the specimen is 0.927. The technique of random number generation is used to generate the locations and orientations of microcracks which is the same as the one used earlier in this paper. Ten crack arrays are generated for each crack density of the specimen; one of the plates has six microcracks and the other has 20. The effective Young's moduli for each array are calculated. Figures 13 and 14 show the results of the present method for rectangular plates which had six and 20 microcracks, respectively. The results show the same range of the effective Young's moduli for two groups plates with microcracks and are in good agreement with the experimental results (Carvalho and Lauz, 1996).

## 5. Conclusion

A general method for solving the plane elasticity problem of finite plates with multiple microcracks has been presented. Numerical results show that the present method is accurate and efficient for evaluating the SIFs and the effective Young's moduli. When calculating the effective moduli of plates containing random cracks, the crack distribution are obtained by dividing the plates into meshes and placing one crack randomly inside each mesh. The calculated results agree well with

the experimental data (Vavakin and Salganik, 1975; Carvalho and Labuz, 1996) and Huang's numerical results which were obtained by using the completely random crack locations (with the only restriction of non-intersecting cracks), indicating that the effect of the random number generator on the effective elastic moduli is slight. For randomly oriented cracks, the mean of the moduli is close to the solution from the differential method; for parallel cracks, the range of variations in the moduli is below that for the dilute or non-interacting solution and above that for the differential solution.

### Acknowledgement

The research presented here was supported by the National Natural Science Foundation of China (No. 19704100) and the National Natural Science Foundation of Chinese Academy of Sciences (Project KJ951-1-201).

### References

- Bai, Y.L., Ke, F.J., Xia, M.F., 1991. Formulation of statistical evolution of microcracks in solids. *Acta Mechanica Sinica* 7, 59–66.
- Benveniste, Y., 1986. On the Mori–Tanaka method in cracked solids. *Mech. Res. Comm.* 13 (4), 193–201.
- Breyse, D., Schmitt, N., 1991. A test for delaying localization in tension. Numerical interpretation through a probabilistic approach. *Cement and Concrete Research* 21, 963–974.
- Budiansky, B., O'Connell, R.J., 1976. Elastic moduli of a cracked solid. *Int. J. Solids Struct.* 12, 81–95.
- Carvalho, F.C.S., Labuz, J.F., 1996. Experiments on effective elastic modulus of two-dimensional solids with cracks and holes. *Int. J. Solids Struct.* 33, 4119–4130.
- Chau, K.T., Wong, H.C., 1997. Effective moduli of microcracked rocks: theories and experiments. *Int. J. Damage Mech.* 6, 258–277.
- Chiaia, B., Vervuurt, A., Van Mier, J.G.M., 1997. Lattice model evaluation of progressive failure in disordered particle composites. *Eng. Frac. Mech.* 57, 301–318.
- Christensen, R.M., Lo, K.H., 1979. Solutions for effective shear properties in three phase sphere and cylinder models. *J. Mech. Phys. Solids* 27, 315–330.
- Curtin, W.A., Scher, H., 1990. Brittle fracture in disordered materials: a spring network model. *J. Mater. Res.* 5, 535–553.
- Diao, X., 1996. A new statistical damage theory. *J. mater. Sci.* 31, 3879–3885.
- Fond, C., Berthaud, Y., 1995. Extensions of the pseudo tractions technique for friction in cracks, circular cavities and external boundaries; effect of the interactions on the homogenised stiffness. *Int. J. Frac.* 74, 1–28.
- Gibiansky, L.V., Torquato, S., 1993. Link between the conductivity and elastic moduli of composite materials. *Phys. Rev. Lett.* 71, 2927–2930.
- Gibiansky, L.V., Torquato, S., 1996. Bounds on the effective moduli of cracked materials. *J. Mech. Phys. Solids* 44, 233–242.
- Gross, D., 1982. Spannungsintensitätsfaktoren von ribsystemen. *Ing. Arch.* 51, 301–310.
- Han, X.L., Wang, T.C., 1996. In: Wang, T.C., Chou, T.W. (Eds.), *Progress in Advanced Materials and Mechanics*. Peking University Press, Beijing, pp. 688–693.
- Harlow, D.G., Phoenix, S.L., 1991. Approximations for the strength distribution and size effect in an idealized lattice model of materials breakdown. *J. Mech. Phys. Solids* 39, 173–200.
- Hashin, Z., 1983. Analysis of composite materials—a survey. *J. of Appl. Mech.* 50, 481–505.
- Haskin, Z., 1988. The differential scheme and its application to cracked materials. *J. Mech. Phys. Solids* 36, 719–734.

- Hashin, Z., Shtrikman, S., 1963. A variational approach to the theory of the elastic behavior of the multiphase materials. *J. Mech. Phys. Solids* 1, 127–140.
- Herrmann, H.J., Roux, S., 1990. *Statistical Models for the Fracture of Disordered Media*. North-Holland, Amsterdam.
- Huang, Y., Chandra, A., Jiang, Z.Q., Wei, X., Hu, K.X., 1996. The numerical calculation of two-dimensional effective moduli for microcracked solids. *Int. J. Solids Struct.* 33, 1575–1586.
- Jiang, Z.Q., Chandra, A., Huang, Y., 1996. A hybrid micro–macro BEM with micro-scale inclusion-crack interactions. *Int. J. Solids Struct.* 33 (16), 2309–2329.
- Ju, J.W., Chen, T.M., 1994. Effective elastic moduli of two-dimensional brittle solids with interacting microcracks, Part I: Basic formulations. *J. Appl. Mech.* 61, 349–357.
- Kachanov, M., 1987. Elastic solids with many cracks: a simple method of analysis. *Int. J. Solids Struct.* 23, 23–43.
- Kachanov, M., 1992. Effective elastic properties of cracked solids: critical review of some basic concepts. *Appl. Mech. Rev.* 45, 304–335.
- Kachanov, M., 1994. Elastic solids with many cracks and related problems. In: *Advances in Applied Mechanics* 30, 259–445.
- Krajcinovic, D., 1996. *Damage Mechanics*. Elsevier, Amsterdam, The Netherlands.
- Krajcinovic, D., 1997. Effective materials properties in the limit of large defect concentration. *Eng. Fract. Mech.* 57 (2/3), 227–240.
- Mazars, J., 1983. Probabilistic Aspects of Mechanical Damage in Concrete Structures. In: Sih, G. (Ed.), *Fracture mechanics technology applied to material evaluation*. M. Nijhoff, The Hague, The Netherlands, pp. 180–191.
- Milton, G.W., 1984. Correlation of the electromagnetic and elastic properties of composites and microgeometries corresponding with effective medium approximation. In: Johnson, D.L., Sen, P.N. (Eds.), *Physics and Chemistry of Porous Media*. American Institute of Physics.
- Mori, T., Tanaka, K., 1973. Average stress in matrix and average elastic energy of materials with misfitting inclusions. *Acta Metall.* 21, 571–574.
- Murakami, Y., 1987. *Stress Intensity Factors Handbook*. World Publishing Corporation, Pergamon Press.
- Muskhelishvili, N.I., 1953. *Some Basic Problems of Mathematical Theory of Elasticity*. P. Noordhoff, Groningen.
- Nemat-Nasser, S., Hori, M., 1993. *Micromechanics: Overall Properties of Heterogeneous Materials*, North-Holland, Amsterdam, The Netherlands.
- Ostoja-Starzewski, M., Lee, J.D., 1996. Damage maps of disordered composites: a spring network approach. *Int. J. Frac.* 75, R51–R57.
- Ray, P., Chakrabarti, B.K., 1985. A microscopic approach to the statistical fracture analysis of disordered brittle solids. *Solid State Communications* 53, 477–479.
- Renaud, V., Kondo, D., Henry, J.P., 1996. Computations of effective moduli for microcracked materials: a boundary element approach. *Computational Materials Science*, Vol. 5, 227–237.
- Schlangen, E., Garboczi, E.J., 1996. New method for simulating fracture using an elastically uniform random geometry lattice. *Int. J. Engng Sci.* 34, 1131–1144.
- Skjeltorp, A.T., Meakin, P., 1988. Fracture in microsphere monolayers studied by experiment and computer simulation. *Nature* 335, 424–426.
- Torquato, S., 1992. Connection between morphology and effective properties of materials from the microstructure, Torquato, S. and Krajcinovic, D. (Eds.), *AMD*, Vol. 147. ASME, New York, NY.
- Vavakin, A.S., Salganik, R.L., 1975. Effective characteristics of nonhomogeneous media with isolated nonhomogeneities. *Izv. Akad. Nauk. SSSR, MTT*, No. 3, pp. 65–75.
- Willis, J.R., 1981. Variational and related methods for the overall properties of composites. *Adv. Appl. Mech.* 21, 1–78.